



AN1012 APPLICATION NOTE

Predicting the Battery Life and Data Retention Period of NVRAMs and Serial RTCs

INTRODUCTION

Standard SRAM devices have the advantage, over EEPROM and Flash memory, of high write-speed when used as main memory for a processor or microcontroller. Their disadvantage is that they are volatile, and lose their contents as soon as the power supply is removed (whether this is for a prolonged period due to being turned off, or due to an unexpected glitch or loss of the power supply).

STMicroelectronics manufactures a line of non-volatile SRAMs (NVRAMs), known as ZEROPOWER® or TIMEKEEPER® NVRAMs, Supervisors, and Serial RTCs which offer the best of both worlds: memory devices that are non-volatile like EEPROM, yet have the fast access of SRAM. These devices consist of an array of low-power CMOS SRAM, plus a small long-life lithium power cell (along with a high-accuracy quartz crystal, in the case of the TIMEKEEPER). While the external power supply is within its specified limits, the memory behaves as standard SRAM; but as soon as the external power supply strays out of tolerance, the SRAM becomes write-protected, and its contents are preserved by a small trickle current supplied by the internal power cell.

Unlike EEPROM, where the data contents are guaranteed to be preserved for 10 years (and typically last for much longer), the contents of NVRAM will only be retained while the internal cell is able to supply sufficient current to maintain the array. This document summarizes the factors involved in predicting the battery life, and consequently data retention under various operating conditions.

Many of the ZEROPOWER, TIMEKEEPER, Supervisor, and Serial RTC devices are packaged in a 600mil DIP CAPHAT™, a Hybrid DIP and BGA, or a 330mil SOIC SNAPHAT®. The SNAPHAT (shown in [Figure 1.](#)) has a removable top that includes both the long-life lithium cell and, in the case of the TIMEKEEPER, a high-accuracy crystal.

STMicroelectronics has shipped several million SNAPHATs that have been used in a broad range of applications. From PC-based systems to high-end workstations, telecommunications, consumer, and automotive applications, these products have provided highly reliable data storage for the electronics industry.

Figure 1. Standard ZEROPOWER, TIMEKEEPER, Supervisor, and Serial RTC Packages

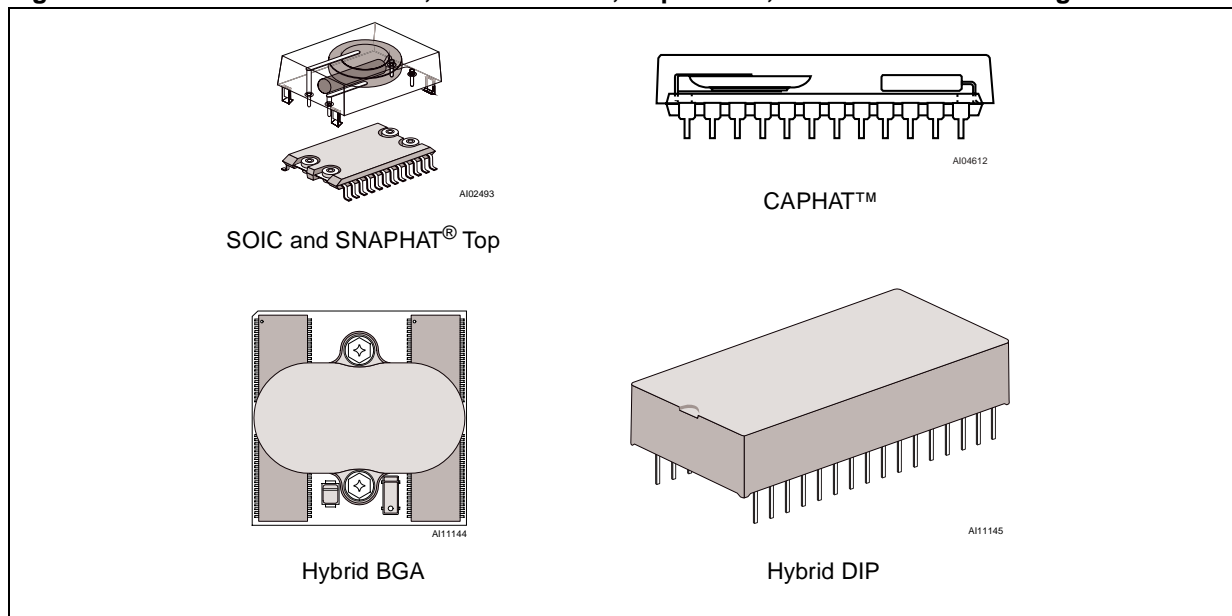

TABLE OF CONTENTS

INTRODUCTION	1
Figure 1. Standard ZEROPOWER, TIMEKEEPER, Supervisor, and Serial RTC Packages	1
PROCESS TECHNOLOGY	4
Table 1. ZEROPOWER and TIMEKEEPER [®] Product Categories	4
Figure 2. Four-Transistor (4T) SRAM Cell	4
BATTERY TECHNOLOGY	5
Figure 3. (A) BR1225 Discharge Rate and (B) BR1632 Discharge Rate	5
BATTERY BACK-UP CURRENT - PREDICTING DATA RETENTION TIME	6
Storage Life	6
Figure 4. Predicted Battery Storage Life versus Temperature	6
Calculating Storage Life	7
Capacity Consumption	7
Calculating Capacity Consumption	8
4T CELL DEVICES	8
TIMEKEEPER PRODUCTS	9
Figure 5. Block Diagram of a TIMEKEEPER [®] Device	9
TIMEKEEPER[®] Register Map	10
Table 2. Typical TIMEKEEPER (M48T37Y) Register Map	10
Table 3. Typical I _{BAT} Current for TIMEKEEPER Devices	10
TIMEKEEPER[®] Evolution	11
Figure 6. M48T02/12 Data Retention Lifetime vs. Temperature (120mAh, 100% Battery Back-up)11	
Figure 7. M48T08/18 Data Retention Lifetime vs. Temperature (120mAh, 100% Battery Back-up)12	
Figure 8. M48T58/59 Data Retention Lifetime vs. Temperature (48mAh, 100% Battery Back-up) 13	
Figure 9. M48T58/59 Data Retention Lifetime vs. Temperature (120mAh, 100% Battery Back-up)13	
Figure 10.M48T35/37 Data Retention Lifetime vs. Temperature (48mAh, 100% Battery Back-up) 14	
Figure 11.M48T35/37 Data Retention Lifetime vs. Temperature (120mAh, 100% Battery Back-up)14	
Table 4. SNAPHAT Part Numbers.	15
SUPERVISOR PRODUCTS	15
CHOOSING SRAM	16
Table 5. M40Z300 (120mAh SNAPHAT) Data Retention Life vs. SRAM Type.	16
Table 6. M48T201Y (Commercial, 120mAh SNAPHAT) Data Retention Life vs. SRAM Type ...	17
INDUSTRIAL TEMPERATURE DEVICES	17
U.L. RECOGNITION and RECYCLING	17
SUMMARY	18

APPENDIX A.PRODUCT DATA	19
Table 7. Data for ZEROPOWER [®] and TIMEKEEPER [®] Devices	19
Table 8. Data from Hybrid/Module Devices (V _{CC} duty cycle = 0%)	19
APPENDIX B.ZEROPOWER PRODUCTS	20
Table 9. Data from M48Z02/12 Devices (available only in CAPHAT™ - BR1225, 48mAh)	20
Table 10. Data from M48Z02 Device (Industrial; available only in CAPHAT, BR1632, 120mAh) ..	20
Table 11. Data from M48Z08/18, M48Z58, and M48Z58Y Devices (Commercial)	21
Table 12. Data from M48Z58Y Device (Industrial)	21
Table 13. Data from M48Z35/Y/AV/AY Devices (Commercial)	22
Table 14. Data from M48Z35Y/AY Devices (Industrial)	22
APPENDIX C.TIMEKEEPER[®] PRODUCTS	23
Table 15. Data from M48T02/12 Devices (available only in CAPHAT™ - BR1632, 120mAh)	23
Table 16. Data from M48T08/Y/18, M48T58/Y, and M48T59/Y Devices	23
Table 17. Data from M48T59Y Industrial Temperature (MH6) Device	24
Table 18. Data from M48T35/Y/AV/AY and M48T37V/Y Devices	24
Table 19. Data from M48T35Y/AV, M48T37V/Y Industrial Temperature (MH6) Devices	25
Table 20. Data from M48T86 Device	25
APPENDIX D.SERIAL RTC PRODUCTS	26
Table 21. Data from M41T56/C64/94/315 and M41ST84/85/87/95 Ind. Temp. (MH6) Devices ..	26
Table 22. Data from M41T00/S, M41T11, and M41T81/S Industrial Temperature (MH6) Devices.	27
REVISION HISTORY	28
Table 23. Document Revision History	28
CONTACT INFORMATION	28

PROCESS TECHNOLOGY

The ZEROPOWER[®], TIMEKEEPER[®], Supervisor, and Serial RTC families consist of a broad range of products that encompass various technologies. These products can be divided into eight categories, as shown in Table 1. The SRAM array is generally based on a 6-transistor or 4-transistor cell, as indicated by the Categories (6T and 4T). Figure 2. illustrates a one-bit storage cell from a 4-transistor SRAM cell.

The Hybrid devices (also known as Module devices) contain individually packaged analog circuitry and SRAM. They are not covered in this document, except for the table of values for typical battery lifetimes in APPENDIX A., page 19.

Table 1. ZEROPOWER and TIMEKEEPER[®] Product Categories

Category	Devices
ZEROPOWER (4T cell)	M48Z02, M48Z12, M48Z08, M48Z18, M48Z58/Y, M48Z35/Y/AV/AY
ZEROPOWER (6T cell)	M48Z32V, M616Z08
ZEROPOWER Hybrid	M48Z128/Y, M48Z129V, M48Z512A/AY, M48Z2M1V/Y
TIMEKEEPER (4T cell)	M48T08/Y, M48T58/Y, M48T59/Y, M48T35/Y/AV/AY, M48T37V/Y
TIMEKEEPER (6T cell)	M48T86
TIMEKEEPER Hybrid	M48T128V/Y, M48T129V, M48T248Y, M48T251Y, M48T254V, M48T512Y
Supervisors	M40SZ100W, M40Z111/W, M40Z300/W, M48T201V/Y, M48T212V/Y, M48T224W
Serial RTCs (6T cell)	M41T00/S, M41T11, M41T56, M41T56C64, M41T81/S, M41T94, M41T315V/Y, M41ST84Y, M41ST84W/Y, M41ST85W/Y, M41ST87W/Y, M41ST95Y/W

Figure 2. Four-Transistor (4T) SRAM Cell

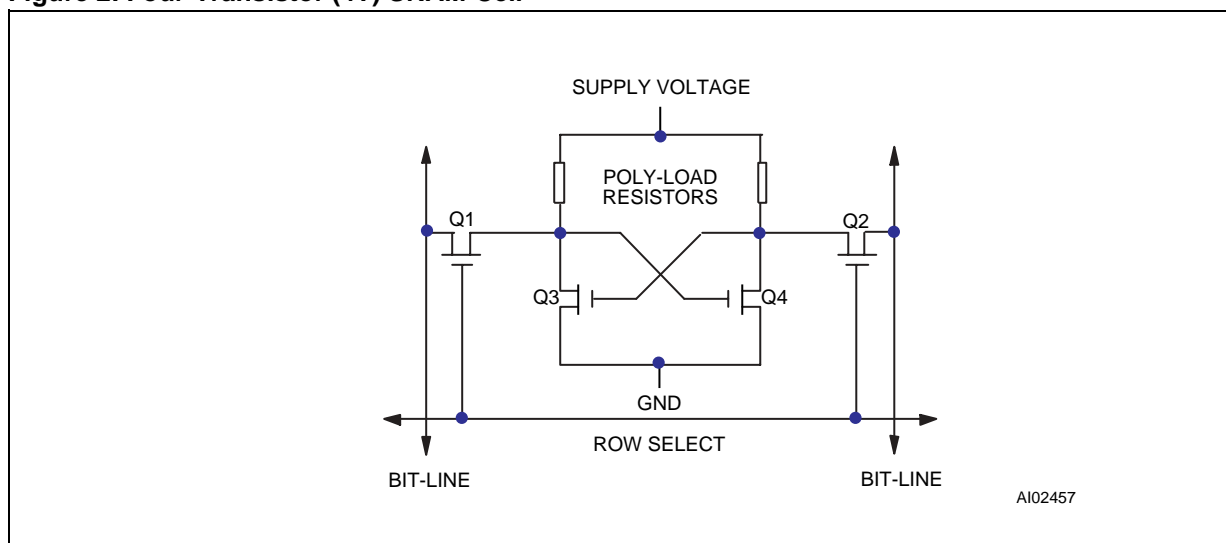

The first devices, released in 1982, were based on a conventional 6T, full-CMOS, SRAM design. These were specified for low-voltage data retention, and were built to stringent manufacturing and test specifications. With data retention currents of less than 150nA at 70°C, these devices were designed to retain data in battery back-up for at least 10 years over the full commercial temperature range.

Newer devices have since been released. They use 4T, CMOS SRAM arrays. By using two poly-R resistors in place of the pull-up transistors of full-CMOS design, the 4T cell is much smaller than the 6T equivalent. Die size is dramatically reduced because the poly-R resistors can be stacked on top of n-channel pull-down MOSFETs in the cell. This leads to a net reduction in the device costs. Although the current drawn from the lithium cell is increased, the devices have been specified to outlast the useful life of most equipment in which they are used.

BATTERY TECHNOLOGY

STMicroelectronics uses both, the BR1225 and the BR1632 lithium button cell batteries. These have charge capacities of 48mAh and 120mAh, respectively. Their constituents have non-toxic and non-corrosive characteristics, and are chemically and thermally stable before, during, and after discharge. This makes these cells particularly attractive for use in electrical components.

They contain a solid carbon cathode that is pressed into a tablet of predetermined weight and height. The anode consists of high-purity lithium metal. The electrolyte is based on an organic solvent instead of the corrosive alkaline or acidic solution found in most conventional batteries. This greatly reduces the likelihood of internally-induced cell leakage, and reduces the ill effects in cases of externally-induced cell leakage. The cell is then crimp-sealed with a polypropylene grommet.

ST has conducted extensive tests on these cells, at temperatures up to 85°C. Destructive analysis was conducted (post-stress), in order to measure such factors as weight loss and remaining charge capacity. The analysis determined that the cells were drying out, and that the weight loss was due to electrolyte evaporation. Models were developed to predict the nominal rate of electrolyte loss, and how this would be reduced by adding a second level of encapsulation. This proprietary secondary seal encapsulation, adopted by ST, has been found to provide up to a two-fold reduction of the electrolyte loss rate.

Both cells produce a nominal 2.9V output with a flat discharge curve until the end of their effective lives, and thus confirms that both are suitable for providing battery backup to low leakage CMOS SRAMs (see [Figure 3](#)).

Figure 3. (A) BR1225 Discharge Rate and (B) BR1632 Discharge Rate

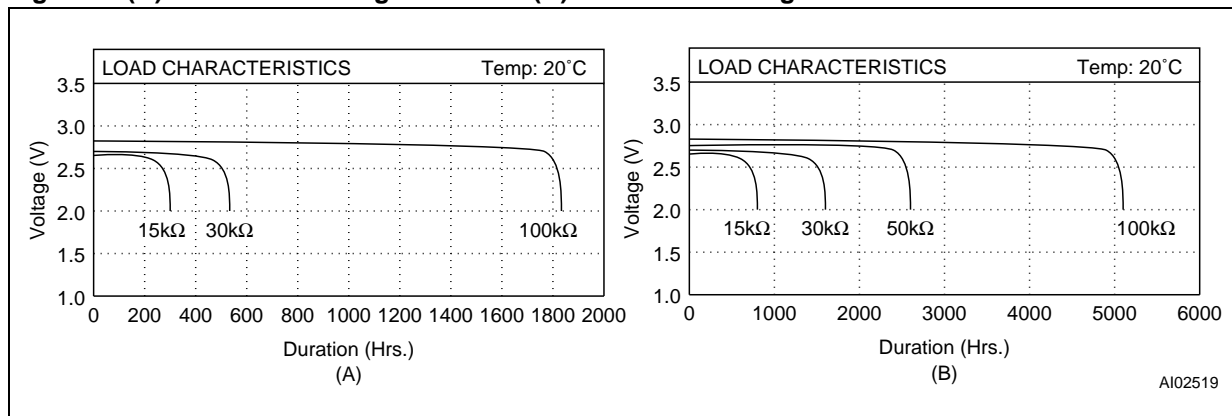

BATTERY BACK-UP CURRENT - PREDICTING DATA RETENTION TIME

A ZEROPOWER®, TIMEKEEPER®, Supervisor, or Serial RTC device will reach the end of its useful life for one of two reasons:

- Capacity Consumption
It becomes discharged, having provided current to the SRAM (and to the oscillator in the case of the TIMEKEEPER) in the battery back-up mode.
- Storage Life
The effects of aging will have rendered the cell inoperative before the stored charge has been fully consumed by the application.

The two effects have very little influence on each other, allowing them to be treated as two independent but simultaneous mechanisms. The data retention lifetime of the device is determined by which ever failure mechanism occurs first.

Storage Life

Storage Life, resulting from electrolyte evaporation, is primarily a function of temperature. Figure 4. illustrates the predicted storage life of the BR1225 battery versus temperature. The results are derived from temperature-accelerated life test studies performed at STMicroelectronics. For the purpose of testing, a cell failure is defined as the inability of a cell, stabilized at 25°C, to produce a 2.4V closed-circuit voltage across a 250kΩ load resistor.

The two lines, SL_{1%} and SL_{50%}, represent different failure rate distributions for the cell's storage life. At 60°C, for example, the SL_{1%} line indicates that the battery has a 1% chance of failure 28 years into its life, and the SL_{50%} line shows that the battery has a 50% chance of failure at the 50 year mark. The SL_{1%} line represents the practical onset of wear out, and can be considered the worst case Storage Life for the cell. The SL_{50%} line can be considered to be the normal, or average, life. As indicated by the curves in Figure 4., Storage Life does not become a limiting factor to overall Battery Life until temperatures in excess of 60°C to 70°C are involved.

As an approximation, $SL_{50\%} = 14270 \times (0.91)^T$, and $SL_{1\%} = 8107 \times (0.91)^T$, when $20^\circ\text{C} < T < 90^\circ\text{C}$.

Figure 4. Predicted Battery Storage Life versus Temperature

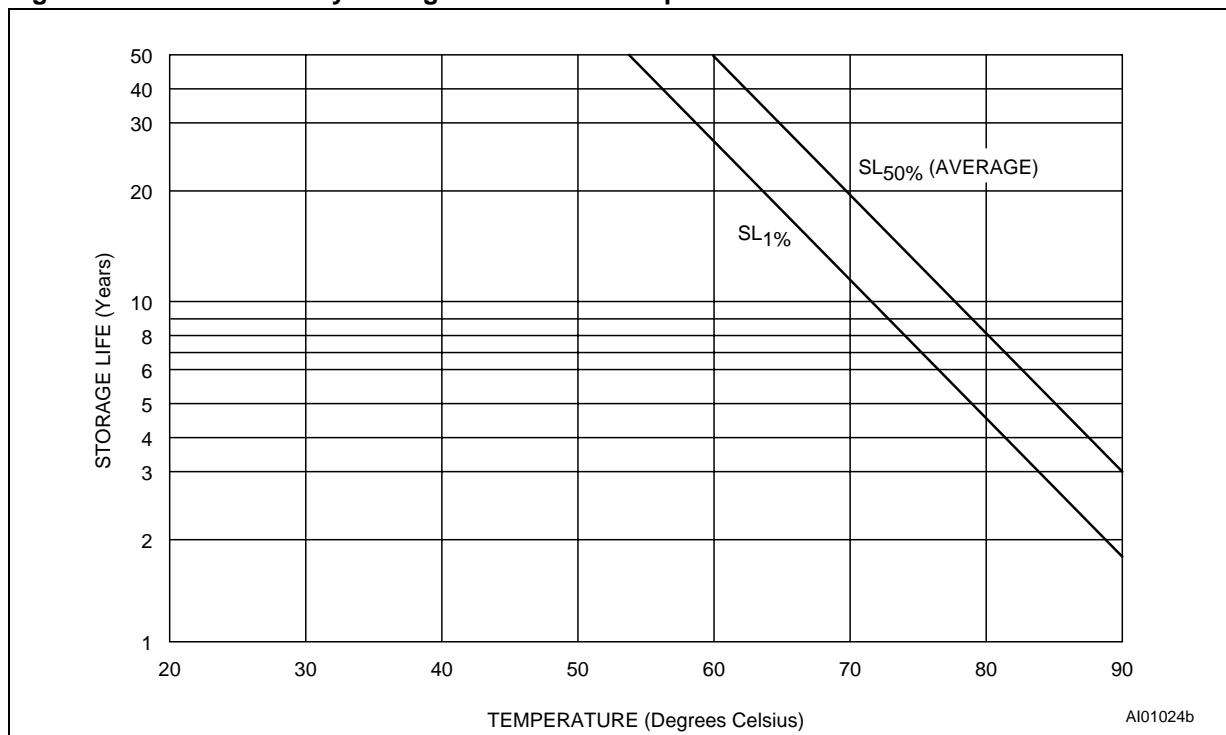

Calculating Storage Life

Only the user can estimate predicted Storage Life in a given design because the ambient temperature profile is dependent upon application-controlled variables. As long as the ambient temperature is held reasonably constant, the expected Storage Life can be read directly from [Figure 4., page 6](#). If the battery spends an appreciable amount of time at a variety of temperatures, the following formula can be used to estimate predicted Storage Life:

$$\left[\left(\frac{t_1}{T} \times \frac{1}{SL_1} \right) + \left(\frac{t_2}{T} \times \frac{1}{SL_2} \right) + \dots + \left(\frac{t_n}{T} \times \frac{1}{SL_n} \right) \right]^{-1}$$

where,

- t_i/T is the relative proportion (of the total time) during which the device is at ambient temperature TA_i ;
- SL_i is the storage life at ambient temperature TA_i as illustrated in [Figure 4.](#); and
- T is the total time = $t_1 + t_2 + \dots + t_n$.

For example, consider a battery exposed to temperatures of up to 90°C for 600 hrs/yr, and temperatures of 60°C or less for the remaining 8160 hrs/yr. Reading predicted $t_{1\%}$ values from [Figure 4.](#),

- SL_1 is about 1.8 yrs;
- SL_2 is about 28 yrs;
- T is 8760 hrs/yr;
- t_1 is 600 hrs/yr; and
- t_2 is 8160 hrs/yr.

The predicted storage life evaluates to:

$$\left[\left(\frac{600}{8760} \times \frac{1}{1.8} \right) + \left(\frac{8160}{8760} \times \frac{1}{28} \right) \right]^{-1}$$

This predicts that the storage life, in this particular case, is at least 14 years. This is, therefore, better than the normally accepted life time of 10 years.

Capacity Consumption

When V_{CC} is being held by the external power supply within its specified range, the current drawn from the battery is zero. When V_{CC} falls below the Battery Back-up Switch-over Voltage (V_{SO}), the device goes into battery back-up mode and draws all of its current from the battery.

The V_{CC} duty cycle represents the proportion of time, expressed as a percentage, that the device is supplied with power from the external supply, and therefore not drawing current from the battery.

In its battery back-up mode, the array of SRAM cells can be characterized by its data retention (I_{CCDR}) current, caused primarily by the current through the Poly-R load resistors in the 4T technology, as well as also by junction leakage, sub-threshold current, and gate-to-substrate leakage. The total current is referred to as I_{BAT} (the current drawn during battery back-up mode). For ZEROPOWER[®] devices, this is the sum of leakage currents plus the current necessary to maintain the SRAM array. For TIMEKEEPER[®] devices, it is the sum of the array current (including leakage) and the clock current:

$$I_{BAT} = I_{ARRAY} + I_{CLOCK}$$

Many factors need to be taken into account when calculating the I_{BAT} current, including process parameters, working temperature, and the V_{CC} duty cycle.

AN1012 - APPLICATION NOTE

Calculating Capacity Consumption

Capacity consumption is simply calculated by:

$$\frac{\text{BatteryCapacity}}{8760 \times (1 - V_{CC} \text{DutyCycle}/100) \times I_{BAT}}$$

where:

- Battery Capacity is measured in ampere-hours;
- 8760 is the constant for the number of hours there are in a year;
- V_{CC} Duty Cycle is measured as a percentage; and
- I_{BAT} is measured in amperes.

For the M48T35Y, a 32K x 8 TIMEKEEPER[®] device with a 0.048Ah (48mAh) M4T28-BR12SH1 battery, the typical battery current is approximately 2666nA at 70°C.

So, if the V_{CC} Duty Cycle is 50%, the predicted capacity life is:

$$\frac{0.048}{8760 \times 0.5 \times 2666 \times 10^{-9}}$$

and therefore is about 4.11 years at 70°C.

4T CELL DEVICES

In moving to the newer process technologies (e.g., M48Z58 (8K x 8) device), STMicroelectronics has chosen to reduce the active current as well as decrease the die size. The STMicroelectronics HCMOS4PZ process is a 0.6 μm , double-level metal process.

In the standard SRAM memory cell, 6 transistors are formed into a pair of cross-coupled inverters. In the 4T memory cell, the top two p-channel devices are replaced by poly-silicon load resistors (poly-R). This combination allows for significant die size reduction because the poly-R structures can be stacked on top of the active n-channel devices.

There is always at least one direct path constantly leaking current to ground in each cell because of the poly-R structures in each SRAM cell. However, the value of the resistor is extremely high (about $3\text{T}\Omega$ at 25°C), so at a cell voltage of 3V, this leads to a leakage current of 1pA. Multiplying by the number of cells within the array, the array stand-by current can be calculated (i.e. 65.5nA for a 65536-cell array).

The poly-R structure values are dependent on temperature, so the entire array current is very strongly temperature-dependent. [APPENDIX B., page 20](#) shows the expected battery lifetime of an M48Z58 device versus working temperature with a V_{CC} duty cycle of 0%.

The original specification was an expected lifetime of greater than 10 years at 25°C but, in fact, this target is typically achieved even at 70°C. By reducing the temperature, the expected lifetime rises to greater than 20 years (i.e., when the device is operated at 50°C). This change is defined entirely by the temperature sensitivity of the poly-R structures within each SRAM cell.

The M48Z35 also employs the STMicroelectronics HCMOS4PZ process, 4T SRAM cell technology. [APPENDIX B.](#) shows the expected battery lifetime of an M48Z35 device versus working temperature with a V_{CC} duty cycle of 0%. From this we can see that expected lifetime is typically greater than 20 years when operated at 30°C with no external V_{CC} applied, and falls to approximately 2.6 years for continuous battery back-up at 70°C. This is to be expected, due to the increased current consumption inherent in the 4T SRAM cell architecture. It should be noted that this data is based on usage of the SNAPHAT[®] product which includes a 48mAh battery.

TIMEKEEPER PRODUCTS

TIMEKEEPER® products are very similar in construction and operation to ZEROPOWER® products. However, they must be evaluated separately. The current drawn is highly dependent not only on the temperature, but also on whether the oscillator is active. The main components of TIMEKEEPER devices are (see Figure 5.):

- a CMOS RAM array;
- voltage sense and switching circuitry;
- an analog oscillator and clock chain;
- a lithium power cell; and
- a high-accuracy quartz crystal.

Figure 5. Block Diagram of a TIMEKEEPER® Device

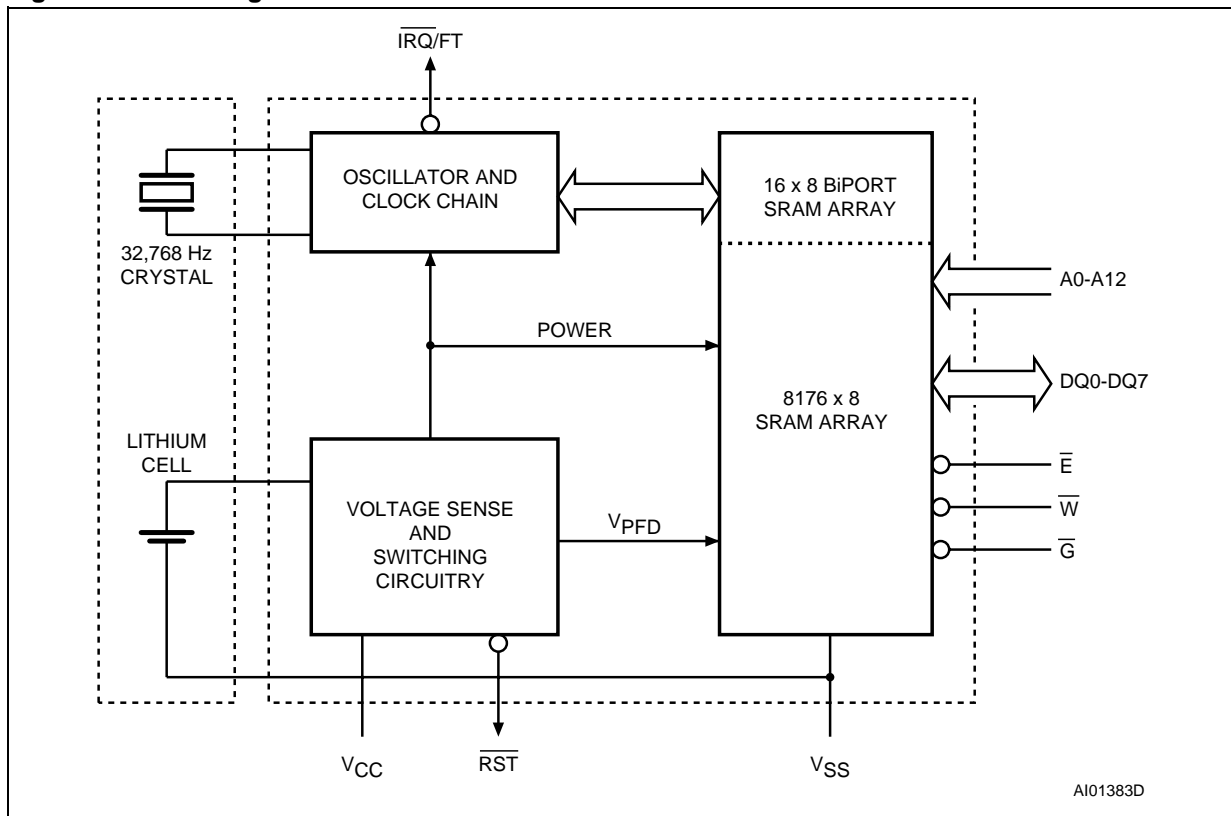

AN1012 - APPLICATION NOTE

TIMEKEEPER® Register Map

Table 2. shows a typical register map for the seconds, minutes, hours, date, day, month, and year fields. This information is stored in Binary Coded Decimal (BCD) format. These basic functions are available on all TIMEKEEPER devices. Additional features (e.g., watchdog timer, alarms, battery low flag, and a wake-up function) have additional registers allocated to them (such as those shown for the M48T37Y in Table 2.). The TIMEKEEPER register locations are constructed from BiPORT™ memory cells which allow data access from two sides. The on-chip system clock connects to one side (the system side) and the user data is output to connections on the other (the user's side). At one-second intervals, clock pulses are generated by the oscillator and clock chain structure. The system side updates the new time in the TIMEKEEPER registers. Each TIMEKEEPER register location (e.g. minutes, hours, day) is then updated as necessary. When the user wants to write a new time, the "W" Bit (the Write Bit) of the Control Register is reset, causing the BiPORT cells to upload the new system time. The user accesses the TIMEKEEPER and array data by executing standard READ/WRITE cycles.

The oscillator and clock chain structure consists of a mixture of analog and digital circuitry, and account for the majority of the I_{BAT} current. Table 3. gives conservative estimates of the currents drawn as a function of technology and working temperature.

Table 2. Typical TIMEKEEPER (M48T37Y) Register Map

Address	Data								Function	Range (in BCD Format)
	D7	D6	D5	D4	D3	D2	D1	D0		
7FFFh	10 Years				Year				Year	00-99
7FFEh	0	0	0	10M	Month				Month	01-12
7FFDh	0	0	10 Date		Date				Date	01-31
7FFCh	0	FT	0	0	0	Day			Day	01-7
7FFBh	0	0	10 Hours		Hours				Hours	00-23
7FFAh	0	10 Minutes			10 Minutes				Minute	00-59
7FF9h	ST	10 Seconds			Seconds				Second	00-59
7FF8h	W	R	S	Calibration					Control	
7FF7h	WDS	BMB4	BMB3	BMB2	BMB1	BMB0	RB1	RB0	Watch	
7FF6h	AFE	0	ABE	0	0	0	0	0	Interrupt	
7FF5h	RPT4	0	AI 10 Date		Alarm Date				A Date	01-31
7FF4h	RPT3	0	AI 10 Hour		Alarm Hour				A Hour	00-23
7FF3h	RPT2	Alarm 10 Minutes			Alarm Minutes				A Minute	00-59
7FF2h	RPT1	Alarm 10 Seconds			Alarm Seconds				A Second	00-59
7FF1h	1000 Years				100 Years				Century	00-99
7FF0h	WDF	AF	0	BL	Z	Z	Z	Z	Flags	

Table 3. Typical I_{BAT} Current for TIMEKEEPER Devices

		Typical at 20°C		Typical at 70°C	
Capacity	Technology	Array	Clock	Array	Clock
64 Kbit	4T Cell	40nA	497nA	511nA	619nA

TIMEKEEPER® Evolution

TIMEKEEPER products have seen a continuous evolutionary cycle since their initial market introduction nearly 20 years ago.

M48T02 and M48T12. The first TIMEKEEPER products released were the MK48T02 and MK48T12 which offered 2K x 8 RAM and employed the STMicroelectronics 2.0 μm Spectrum™ CMOS technology. When released, these products included a BR1225 lithium cell with a specified 39mAh capacity. This combination offered the user approximately 3.5 years of continuous battery back-up life. Since that time, the devices have been moved to the 4T cell technology (HCMOS4PZ) and a CAPHAT™ package revision which includes a larger capacity lithium cell (120mAh BR1632) capacity, and new part numbers (M48T02/12). These changes increased the expected battery life to 19 years at 60°C.

Figure 6. shows expected battery lifetime versus temperature with 100% battery back-up. The data shows that by operating the devices at various temperatures, designers can expect a battery life approaching 20 years under most conditions.

Figure 6. M48T02/12 Data Retention Lifetime vs. Temperature (120mAh, 100% Battery Back-up)

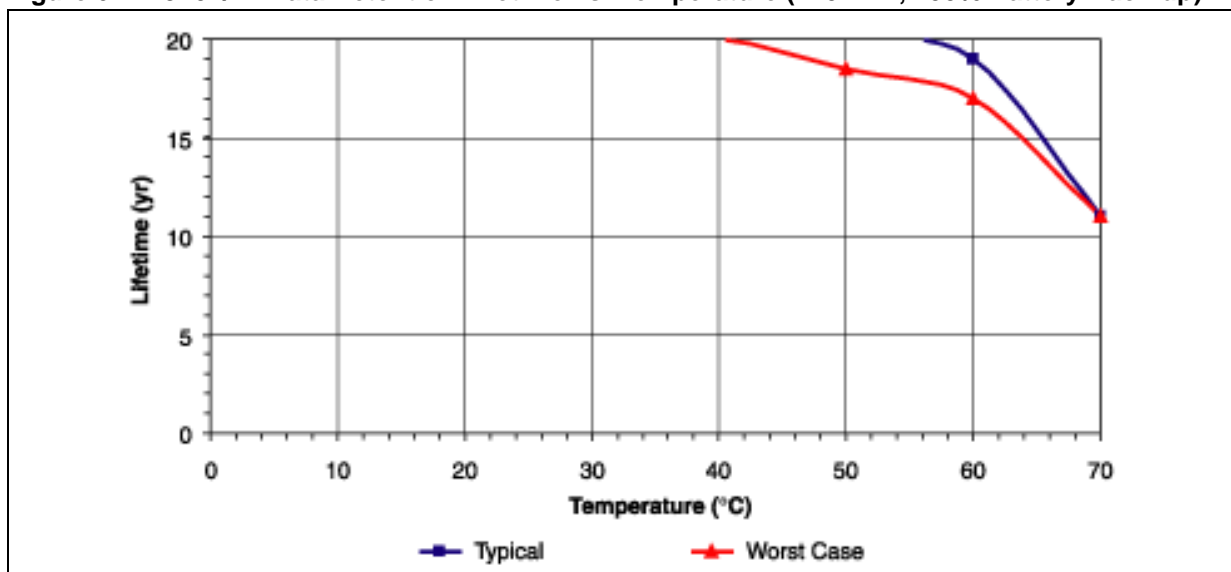

AN1012 - APPLICATION NOTE

M48T08 and M48T18. The next TIMEKEEPER® to be released was the MK48T08/18 family, which has an 8K x 8 SRAM array. By using the more advanced 1.2µm HCMOS3 process and refining the on-board oscillator, STMicroelectronics was able to offer a nearly three-fold increase in battery lifetime, even though the array size had increased by a factor of four. This product was later converted to the 0.6µm, double-level metal HCMOS4PZ process for 4T SRAM cells. The battery was then upgraded to 120mAh for the CAPHAT™ package revision (part numbers M48T08/18), which provides a battery life of at least 10 years across the Commercial temperature range (0°C to 70°C, see [Figure 7](#)).

In the M48T08/18 data sheet, the battery lifetime (t_{DR} , data retention time) has been specified as 10 years or greater across the Commercial temperature range (for a 0% V_{CC} duty cycle).

Figure 7. M48T08/18 Data Retention Lifetime vs. Temperature (120mAh, 100% Battery Back-up)

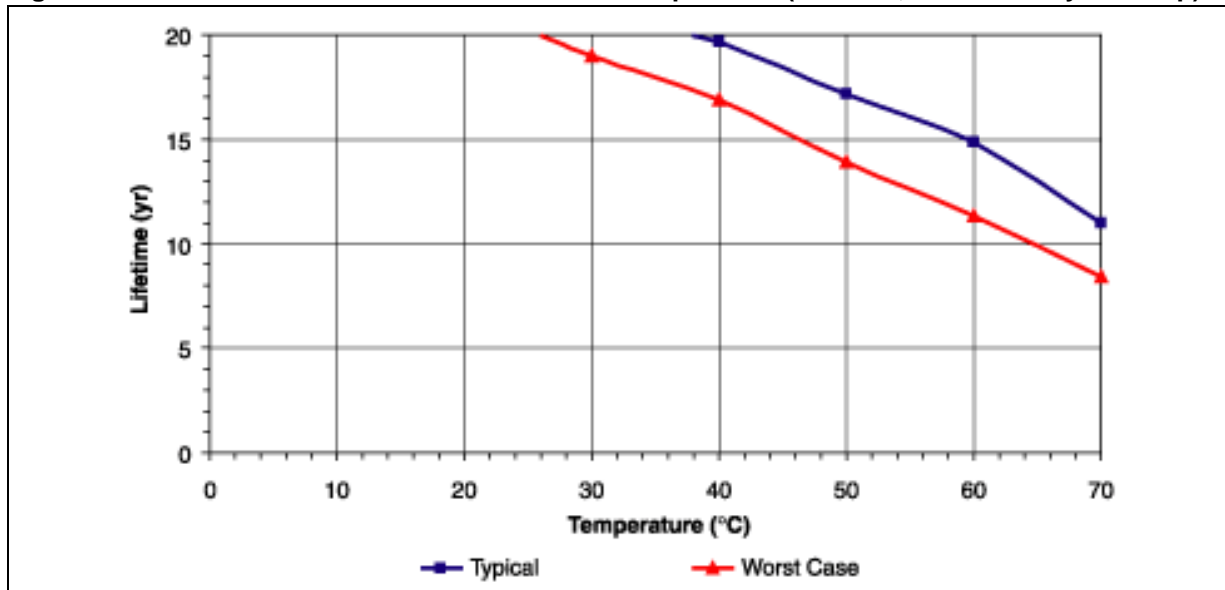

M48T58 and M48T59. The next TIMEKEEPER® products were the M48T58 and M48T59. These are fabricated on the 0.6µm, double-level metal HCMOS4PZ process for 4T SRAM cells. The M48T59 offers additional features such as watchdog timers, programmable alarms, and alarm resets.

Table 16., page 23, APPENDIX C., page 23, Figure 8., and Figure 9. show the extent to which the data retention of these devices is more dependent on temperature. Higher temperatures cause lower resistor values (and therefore, higher currents) because of the negative temperature coefficient of the poly-R resistors.

Data retention lifetimes typically range from 8.6 years (at 30°C) for devices in the CAPHAT™ package, with a 48mAh battery (see Figure 8.), and up to 20 years (and more) for the SNAPHAT package with a 120mAh BR1632 battery (see Figure 9.). As always, several factors effect battery lifetime, including the V_{CC} duty cycle and temperature.

Figure 8. M48T58/59 Data Retention Lifetime vs. Temperature (48mAh, 100% Battery Back-up)

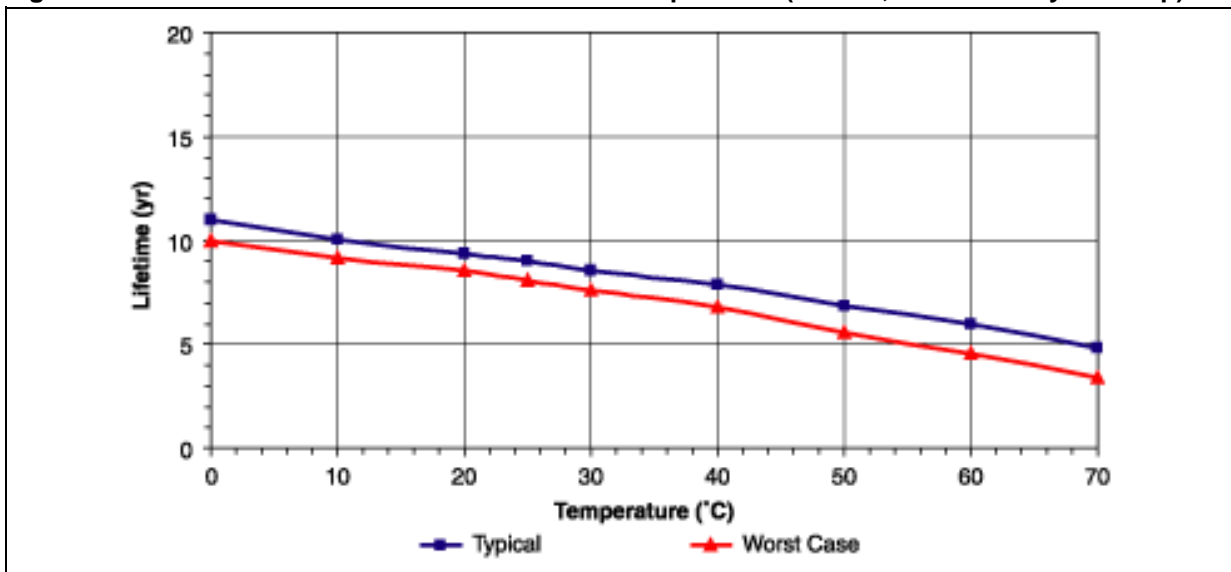
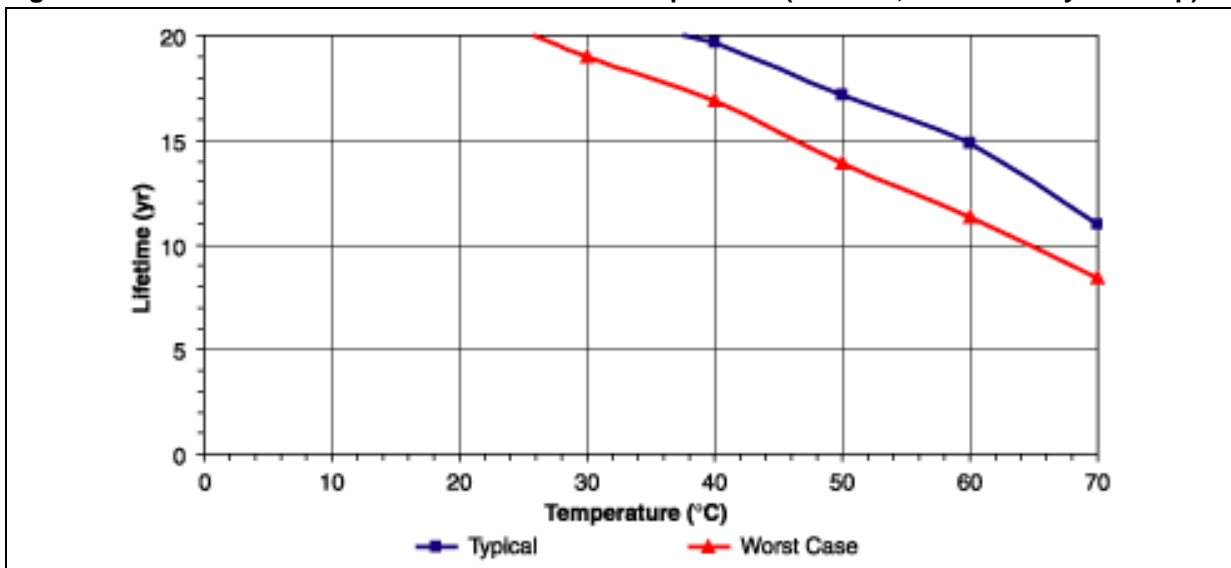

Figure 9. M48T58/59 Data Retention Lifetime vs. Temperature (120mAh, 100% Battery Back-up)



AN1012 - APPLICATION NOTE

M48T35 and M48T37. The M48T35 and M48T37 families use the same technology as the M48T58 and M48T59 devices, but with a 32K x 8 SRAM array. Figure 10, and Figure 11, show the expected battery lifetime versus temperature. The expected battery lifetime (at 30°C with no periods of valid V_{CC}) is typically 6.8 years (this assumes that a 48mAh battery is used, see Figure 10.). Devices in the larger M4T32-BR12SH SNAPHAT[®] package have a data retention lifetime of greater than twice this (almost 17 years, see Figure 11.).

Figure 10. M48T35/37 Data Retention Lifetime vs. Temperature (48mAh, 100% Battery Back-up)

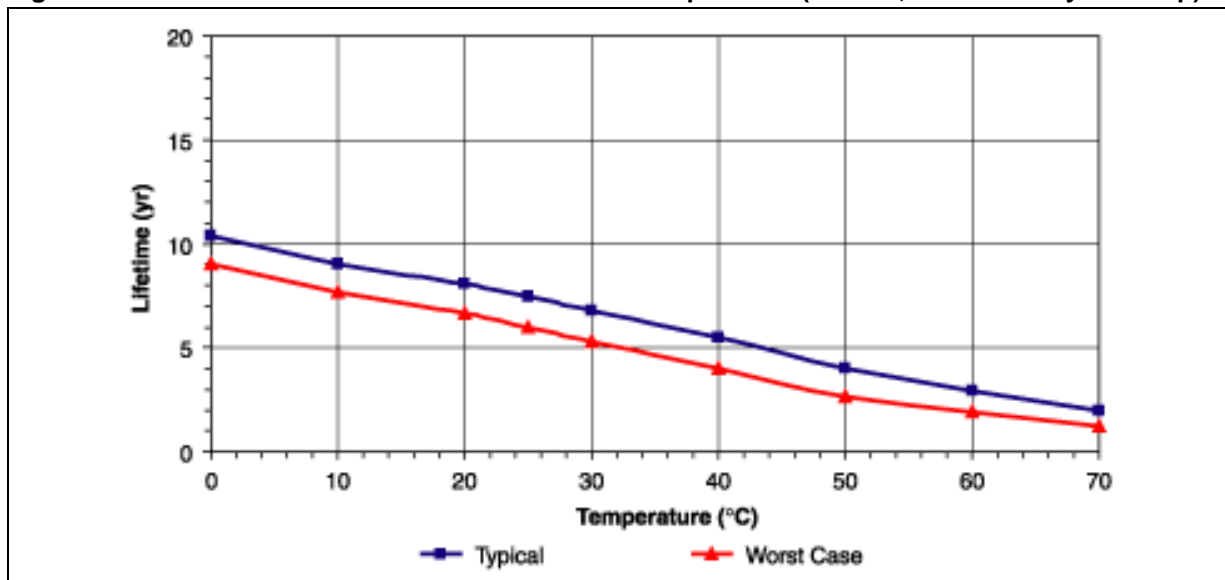
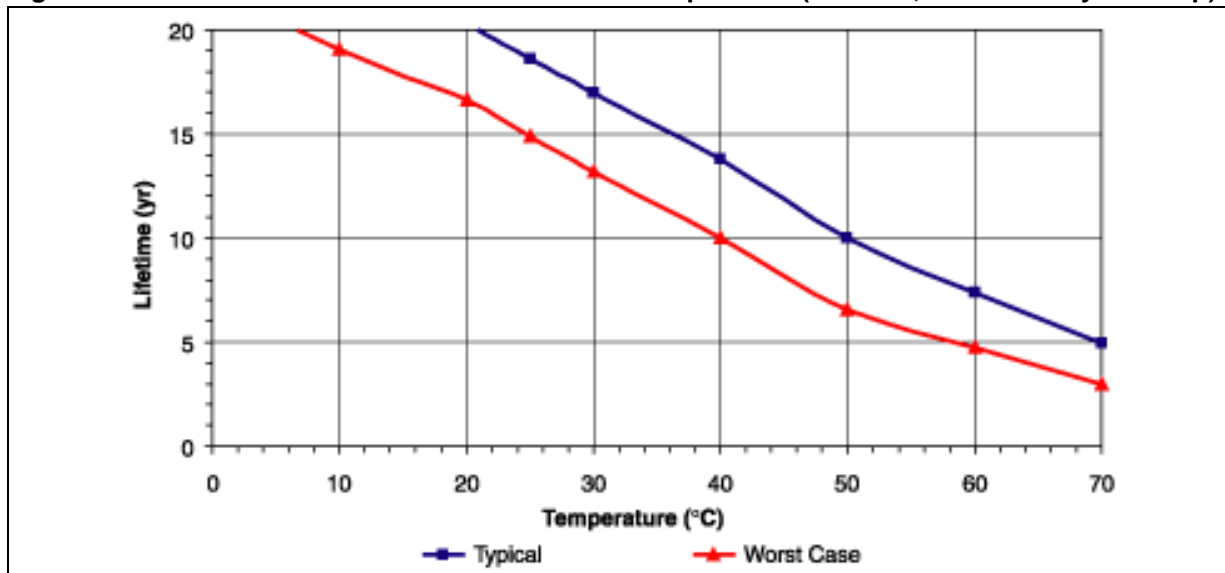

Figure 11. M48T35/37 Data Retention Lifetime vs. Temperature (120mAh, 100% Battery Back-up)



If data retention lifetimes greater than those shown are required, the user is advised to choose the version of the device in a SNAPHAT[®] package. Then, as the battery starts to reach the end of its useful life, it is possible to remove the SNAPHAT top containing the nearly expended cell and replace it with a fresh SNAPHAT top. No data will be lost during the process, provided that the board remains powered-up during the operation (although some time will be lost due to the momentary removal of the 32kHz crystal). [Table 4.](#) shows which SNAPHAT top part numbers are available.

Table 4. SNAPHAT Part Numbers

Part Number	Description	Package
M4Z28-BR00SH	Li Battery (48mAh) for ZEROPOWER products and SUPERVISORS	SNAPHAT
M4Z32-BR00SH	Li Battery (120mAh) for ZEROPOWER products and SUPERVISORS	SNAPHAT
M4T28-BR12SH	Li Battery (48mAh) for TIMEKEEPER products and SUPERVISORS	SNAPHAT
M4T32-BR12SH	Li Battery (120mAh) for TIMEKEEPER products and SUPERVISORS	SNAPHAT

SUPERVISOR PRODUCTS

STMicroelectronics recently introduced a family of ZEROPOWER[®] and TIMEKEEPER[®] Supervisor devices. Supervisors are self-contained units that allow standard low-power SRAMs to be turned into non-volatile memory devices. They monitor and provide V_{CC} input for one or more external SRAMs the same way ZEROPOWER and TIMEKEEPER products do. They use a precision voltage reference and comparator to monitor the V_{CC} input for going out-of-tolerance.

When V_{CC} becomes invalid, the Supervisor's conditioned chip-enable outputs (\overline{E}_{CON}) are forced to their "inactive" state, thereby putting each external SRAM into its own write-protect state. During the power failure, the Supervisor provides the power for the SRAM from the lithium cell within its SNAPHAT top. The Supervisor switches the power source back to the V_{CC} supply as soon as the voltage returns to specified levels.

CHOOSING SRAM

Most low power SRAMs on the market today can be used with both ZEROPOWER® and TIMEKEEPER® Supervisors, although there are some issues that need addressing before finally choosing which SRAM to use.

- The chip enable input, when taken inactive, must disable all the other inputs to the SRAM. This allows inputs to the external SRAMs to be treated as “Don’t care” once V_{CC} falls below $V_{PFD(min)}$.
- The SRAM should guarantee data retention when working at $V_{CC} = 2.0$ volts.
- The chip-enable access time must be sufficient to meet the system needs, taking into account propagation delays on chip enable and output enable.

Most SRAMs specify a data retention current (I_{CCDR}) at 3.0V. Manufacturers generally specify a typical condition for room temperature along with a worst case condition (generally at elevated temperatures). The system level requirements will determine the choice of which value to use. The data retention current value of the SRAMs can then be added to the I_{BAT} value of the Supervisor to determine the total current requirements for data retention. The available battery capacity for the SNAPHAT® of your choice can then be divided by this current to determine the data retention period (see [Capacity Consumption, page 7](#)).

STMicroelectronics offers ultra-low power 5V and 3V 128K x 8 SRAMs, as well as 512K x 8 SRAMs. These SRAMs are available for use with the Supervisor devices in order to provide the longest possible data retention lifetimes. For example, the M48T201Y has an I_{BAT} value of 575nA at 25°C, and 800nA at 70°C. The M40Z300 has an I_{BAT} value of 5nA at 25°C, and 100nA at 70°C. [Table 5](#) indicates typical Data Retention Lifetimes for the M40Z300 ZEROPOWER Supervisor when it is used with a number of commercially available 1 Mbit and 4 Mbit SRAMs. [Table 6., page 17](#) shows the same kind of information for the M48T201Y TIMEKEEPER Supervisor.

Table 5. M40Z300 (120mAh SNAPHAT) Data Retention Life vs. SRAM Type

Size (Mbit)	Product		I_{BAT} (SRAM) (nA)		I_{BAT} (Total) (nA)		Lifetime in Years ⁽¹⁾	
			25°C	70°C	25°C	70°C	25°C	70°C
1	Hynix	HY628100BLLT1-55	1000	10000	1005	10100	13.6	1.4
		HY62V8100BLLT1-70 ⁽²⁾	1000	10000	1005	10100	13.6	1.4
	Renesas	M5M51008DVP-55H	500	10000	505	10100	> 20	1.4
		M5M5V108DVP-70H ⁽²⁾	1000	10000	1005	10100	13.6	1.4
4	Renesas	R1LP0408CSB-5SC	800	8000	805	8100	17.0	1.7
		R1LV0408CSB-5SC ⁽²⁾	500	8000	805	8100	> 20	1.7
8	Renesas	HM62V8100LTTI-5SL	500	10000	505	10100	> 20	1.4
	Samsung	K6X8008T2B-UF5500	N/A	15000	N/A	15100	N/A	0.9

Note: 1. According to the respective manufacturer's data sheets at the time of writing.
 2. 3V device

Table 6. M48T201Y (Commercial, 120mAh SNAPHAT) Data Retention Life vs. SRAM Type

Size (Mbit)	Product		I _{BAT} (SRAM) (nA)		I _{BAT} (Total) (nA)		Lifetime in Years ⁽¹⁾	
			25°C	70°C	25°C	70°C	25°C	70°C
1	Hynix	HY628100BLLT1-55	1000	10000	1075	10800	8.7	1.3
		HY62V8100BLLT1-70 ⁽²⁾	1000	10000	1075	10800	8.7	1.3
	Renesas	M5M51008DVP-55H	500	10000	1075	10800	12.7	1.3
		M5M5V108DVP-70H ⁽²⁾	1000	10000	1575	10800	8.7	1.3
4	Renesas	R1LP0408CSB-5SC	800	8000	1375	8800	10.0	1.6
		R1LV0408CSB-5SC ⁽²⁾	500	8000	1075	8800	12.7	1.6
8	Renesas	HM62V8100LTTI-5SL	500	10000	1075	10800	12.7	1.3
	Samsung	K6X8008T2B-UF5500	N/A	15000	N/A	15800	N/A	0.9

Note: 1. According to the respective manufacturer's data sheets at the time of writing.
2. 3V device

INDUSTRIAL TEMPERATURE DEVICES

Due to ever increasing requirements for portability and operation under extreme environmental conditions, Industrial Temperature versions (–40°C to +85°C) of the M48Z02, M48Z58, M48Z35, M48T35, M48T37, M48T59, M48T201, M40Z300, M40SZ100, and all of our Serial RTC devices have been introduced. This expanded operating range allows these products to perform under more extreme temperatures for applications such as:

- cell phone base stations;
- pay-phones;
- portable equipment;
- land, water, and aircraft instrumentation; and
- industrial control equipment.

These products are indicated by the digit '6' at the end of the sales-type. The Industrial Temperature TIMEKEEPER[®] SNAPHAT[®] top is also designated by the suffix "6." Predicted Data Retention lifetimes are listed in [APPENDIX B., page 20](#) and [APPENDIX C., page 23](#).

U.L. RECOGNITION and RECYCLING

While providing innovative, leading edge products, STMicroelectronics remains committed to safety, including its products, its customers, and the environment. Each device contains reverse-charge protection circuitry, and uses safe Lithium Mono-fluoride batteries. All ZEROPOWER[®], TIMEKEEPER[®], Supervisor, and Serial RTC components are recognized by Underwriter's Laboratory under file number E89556, and are compliant to the LL-94-VO flammability rating.

The unique SNAPHAT packaging consists of a 330mil SOIC device and a separate, "snap-on" SNAPHAT, which includes both the lithium power cell, and in the case of TIMEKEEPER product, a high accuracy crystal. The SNAPHAT is removable and can be replaced, providing the added benefit of proper disposal or recycling that has not been available before with NVRAMs. Various companies offer recycling and safe disposal of scrap lithium cells.

SUMMARY

Battery life and Data Retention for ZEROPOWER® and TIMEKEEPER® products are primarily functions of two factors:

- Capacity Consumption, and
- Storage Life of the lithium button cell battery.

Due to the fact that Storage Life (caused by electrolyte evaporation) has little effect at temperatures below 60°C, the Data Retention of most applications will be dependent upon the I_{CCDR} of the SRAM being backed-up, as well as the V_{CC} duty cycle. This allows a fairly simple calculation (see [Calculating Capacity Consumption, page 8](#)) to be used to determine the lifetime.

All ST ZEROPOWER products are able to offer at least a 10 year data retention life, typically at 40°C. This may be increased by reducing the temperature, increasing the V_{CC} duty cycle, or in the case of the surface mount SNAPHAT® products, using the larger 120mAh SNAPHAT top.

For the TIMEKEEPER family, battery lifetimes are also affected by the percentage of time the oscillator is in operation. Commercial devices fabricated in 4T technologies provide 7 years of continuous operation at 20°C using the 48mAh M4T28-BR12SH SNAPHAT top, and typically greater than 15 years with the 120mAh M4T32-BR12SH SNAPHAT top.

The ZEROPOWER and TIMEKEEPER Supervisor families allow the user to purchase commodity SRAMs at the best available market price. However, overall Data Retention Life will be determined by the I_{CCDR} of the SRAM selected.

APPENDIX A. PRODUCT DATA

Note: The symbol ">>" means, "... much greater than..."

Table 7. Data for ZEROPOWER® and TIMEKEEPER® Devices

Device	Process Technology	SRAM Cell	Battery Type		I _{BAT} (T = 20°C) (nA)	Typical Data Retention Lifetime ⁽²⁾ (years)
			SNAPHAT ⁽¹⁾	CAPHAT		
M48Z02/12	0.6µm, HCMOS4PZ	4T	n/a	BR1225	9	10
M48Z08/18	0.6µm, HCMOS4PZ	4T	BR1225	BR1225	37	10
M48Z32, M616Z08	0.5µm, HCMOS6	6T	N/A	N/A	23	
M48Z35/Y/AV/AY	0.6µm, HCMOS4PZ	4T	BR1225	BR1225	148	10
M48Z58/Y	0.6µm, HCMOS4PZ	4T	BR1225	BR1225	37	10
M48T02/12	0.6µm, HCMOS4PZ	4T	N/A	BR1632	506	10
M48T08/18	0.6µm, HCMOS4PZ	4T	BR1225	BR1632	535	10
M48T35/Y/AV	0.6µm, HCMOS4PZ	4T	BR1225	BR1632	646	7/10
M48T37Y	0.6µm, HCMOS4PZ	4T	BR1225	N/A	646	7
M48T58/Y	0.6µm, HCMOS4PZ	4T	BR1225	BR1225	535	7
M48T59/Y	0.6µm, HCMOS4PZ	4T	BR1225	BR1225	535	7

Note: 1. The larger capacity BR1632 (120mAh) battery is also available in the SNAPHAT package.

2. The Data Retention Lifetime can be significantly increased by using the SNAPHAT (ZEROPOWER or TIMEKEEPER, as appropriate) with the higher capacity BR1632 battery.

Table 8. Data from Hybrid/Module Devices (V_{CC} duty cycle = 0%)

Device	Specification at T = 25°C (years)	Experimental Conditions (years)		
		0°C	25°C	70°C
M48Z128V/Y	10	>> 20	> 20	2.3
M48Z129V/Y	10	>> 20	> 20	2.3
M48Z512A/AV/AY	10	>> 20	> 20	6.0
M48Z2M1V/Y	10	> 20	> 20	3.1
M48T128V/Y	10	> 20	16.6	2.0
M48T129V/Y	10	> 20	16.6	2.0
M48T512V/Y	10	> 20	19.4	4.8

APPENDIX B. ZEROPOWER PRODUCTS

The tables in this appendix use the terms “typical” and “worst case” to indicate the “mean value at the given temperature” and “mean value plus maximum expected deviation at the given temperature.”

Note: The symbol “>>” means, “... much greater than...”

Table 9. Data from M48Z02/12 Devices (available only in CAPHAT™ - BR1225, 48mAh)

Temperature (°C)	V _{CC} Duty Cycle = 0%		V _{CC} Duty Cycle = 100%, Shelf Life (years)
	Typical (years)	Worst Case (years)	
0	>> 20	>> 20	>> 20
10	>> 20	>> 20	>> 20
20	>> 20	>> 20	>> 20
25	>> 20	>> 20	>> 20
30	>> 20	>> 20	>> 20
40	>> 20	>> 20	>> 20
50	>> 20	>> 20	>> 20
60	> 20	> 20	> 20
70	11.0	11.0	11.0

Table 10. Data from M48Z02 Device (Industrial; available only in CAPHAT, BR1632, 120mAh)

Temperature (°C)	V _{CC} Duty Cycle = 0%		V _{CC} Duty Cycle = 100%, Shelf Life (years)
	Typical (years)	Worst Case (years)	
-40	>> 20	>> 20	>> 20
-30	>> 20	>> 20	>> 20
-20	>> 20	>> 20	>> 20
-10	>> 20	>> 20	>> 20
0	>> 20	>> 20	>> 20
10	>> 20	>> 20	>> 20
20	>> 20	>> 20	>> 20
25	>> 20	>> 20	>> 20
30	>> 20	>> 20	>> 20
40	>> 20	>> 20	>> 20
50	>> 20	> 20	>> 20
60	> 20	15.9	> 20
70	11.0	9.1	11.0
80	4.3	4.3	4.3
85	2.7	2.7	2.7

Table 11. Data from M48Z08/18, M48Z58, and M48Z58Y Devices (Commercial)

Temperature (°C)	CAPHAT or SNAPHAT (BR1225, 48mAh)		SNAPHAT (BR1632, 120mAh)		V _{CC} Duty Cycle = 100%, Shelf Life (years)
	V _{CC} Duty Cycle = 0%				
	Typical (years)	Worst Case (years)	Typical (years)	Worst Case (years)	
0	>> 20	>> 20	>> 20	>> 20	>> 20
10	>> 20	>> 20	>> 20	>> 20	>> 20
20	>> 20	>> 20	>> 20	>> 20	>> 20
25	>> 20	>> 20	>> 20	>> 20	>> 20
30	>> 20	>> 20	>> 20	>> 20	>> 20
40	>> 20	> 20	>> 20	>> 20	>> 20
50	> 20	16.4	>> 20	>> 20	>> 20
60	19.7	10.1	> 20	>20	> 20
70	11.0	5.8	11.0	11.0	11.0

Table 12. Data from M48Z58Y Device (Industrial)

Temperature (°C)	SNAPHAT (BR1632, 120mAh)		V _{CC} Duty Cycle = 100%, Shelf Life (years)
	V _{CC} Duty Cycle = 0%		
	Typical (years)	Worst Case (years)	
-40	>> 20	>> 20	>> 20
-30	>> 20	>> 20	>> 20
-20	>> 20	>> 20	>> 20
-10	>> 20	>> 20	>> 20
0	>> 20	>> 20	>> 20
10	>> 20	>> 20	>> 20
20	>> 20	>> 20	>> 20
25	>> 20	>> 20	>> 20
30	>> 20	>> 20	>> 20
40	>> 20	> 20	>> 20
50	> 20	16.3	>> 20
60	> 20	10.3	> 20
70	11.0	5.8	11.0
80	4.3	3.2	4.3
85	2.7	2.5	2.7

AN1012 - APPLICATION NOTE

Table 13. Data from M48Z35/Y/AV/AY Devices (Commercial)

Temperature (°C)	CAPHAT or SNAPHAT (BR1225, 48mAh)		SNAPHAT (BR1632, 120mAh)		V _{CC} Duty Cycle = 100%, Shelf Life (years)
	V _{CC} Duty Cycle = 0%				
	Typical (years)	Worst Case (years)	Typical (years)	Worst Case (years)	
0	>> 20	>> 20	>> 20	>> 20	>> 20
10	>> 20	> 20	>> 20	>> 20	>> 20
20	>> 20	> 20	>> 20	>> 20	>> 20
25	> 20	17.2	>> 20	>> 20	>> 20
30	> 20	12.9	>> 20	> 20	>> 20
40	14.2	7.5	> 20	18.6	>> 20
50	7.4	3.8	18.4	9.5	>> 20
60	4.5	2.5	11.3	6.2	> 20
70	2.6	1.4	6.5	3.5	11.0

Table 14. Data from M48Z35Y/AY Devices (Industrial)

Temperature (°C)	SNAPHAT (BR1632, 120mAh)		V _{CC} Duty Cycle = 100%, Shelf Life (years)
	V _{CC} Duty Cycle = 0%		
	Typical (years)	Worst Case (years)	
-40	>> 20	>> 20	>> 20
-30	>> 20	>> 20	>> 20
-20	>> 20	>> 20	>> 20
-10	>> 20	>> 20	>> 20
0	>> 20	>> 20	>> 20
10	>> 20	> 20	>> 20
20	>> 20	> 20	>> 20
25	> 20	17.7	>> 20
30	> 20	13.1	>> 20
40	16.7	7.5	>> 20
50	8.4	4.0	>> 20
60	5.4	2.5	> 20
70	3.1	1.4	11.0
80	1.7	0.8	4.3
85	1.4	0.6	2.7

APPENDIX C. TIMEKEEPER[®] PRODUCTSTable 15. Data from M48T02/12 Devices (available only in CAPHAT[™] - BR1632, 120mAh)

Temperature (°C)	V _{CC} Duty Cycle = 0%		V _{CC} Duty Cycle = 100%, Shelf Life (years)
	Typical (years)	Worst Case (years)	
0	> 20	> 20	>> 20
10	> 20	> 20	>> 20
20	> 20	> 20	>> 20
25	> 20	> 20	>> 20
30	> 20	> 20	>> 20
40	> 20	> 20	>> 20
50	> 20	18.5	>> 20
60	19.0	17.0	> 20
70	11.0	11.0	11.0

Table 16. Data from M48T08/Y/18, M48T58/Y, and M48T59/Y Devices

Temperature (°C)	CAPHAT or SNAPHAT (BR1225, 48mAh)		CAPHAT ⁽¹⁾ or SNAPHAT (BR1632, 120mAh)		V _{CC} Duty Cycle = 100%, Shelf Life (years)
	V _{CC} Duty Cycle = 0%				
	Typical (years)	Worst Case (years)	Typical (years)	Worst Case (years)	
0	11.0	10.0	> 20	> 20	>> 20
10	10.1	9.2	> 20	> 20	>> 20
20	9.4	8.5	> 20	> 20	>> 20
25	9.0	8.1	> 20	> 20	>> 20
30	8.6	7.6	> 20	19.0	>> 20
40	7.9	6.8	19.7	16.9	>> 20
50	6.9	5.6	17.1	13.9	>> 20
60	5.9	4.5	14.8	11.3	> 20
70	4.8	3.4	11.0	8.4	11.0

Note: 1. Only available in M48T08 and M48T18 CAPHAT[™].

AN1012 - APPLICATION NOTE

Table 17. Data from M48T59Y Industrial Temperature (MH6) Device

Temperature (°C)	SNAPHAT (BR1632, 120mAh)		V _{CC} Duty Cycle = 100%, Shelf Life (years)
	V _{CC} Duty Cycle = 0%		
	Typical (years)	Worst Case (years)	
-40	> 20	> 20	>> 20
-30	> 20	> 20	>> 20
-20	> 20	> 20	>> 20
-10	> 20	> 20	>> 20
0	> 20	18.6	>> 20
10	19.0	16.9	>> 20
20	17.6	15.3	>> 20
25	16.8	14.4	>> 20
30	15.9	13.3	>> 20
40	14.1	10.9	>> 20
50	11.6	8.3	>> 20
60	9.7	6.3	> 20
70	7.3	4.3	11.0
80	4.3	2.6	4.3
85	2.7	2.2	2.7

Table 18. Data from M48T35/Y/AV/AY and M48T37V/Y Devices

Temperature (°C)	SNAPHAT (BR1225, 48mAh)		CAPHAT or SNAPHAT (BR1632, 120mAh)		V _{CC} Duty Cycle = 100%, Shelf Life (years)
	V _{CC} Duty Cycle = 0%				
	Typical (years)	Worst Case (years)	Typical (years)	Worst Case (years)	
0	10.4	9.0	> 20	> 20	>> 20
10	9.0	7.6	> 20	19.1	>> 20
20	8.1	6.7	> 20	16.6	>> 20
25	7.4	6.0	18.6	14.9	>> 20
30	6.8	5.3	16.9	13.2	>> 20
40	5.5	4.0	13.8	10.0	>> 20
50	4.0	2.6	10.0	6.6	>> 20
60	2.9	1.9	7.4	4.8	> 20
70	2.0	1.2	5.0	3.0	11.0

Table 19. Data from M48T35Y/AV, M48T37V/Y Industrial Temperature (MH6) Devices

Temperature (°C)	SNAPHAT (BR1632, 120mAh)		V _{CC} Duty Cycle = 100%, Shelf Life (years)
	V _{CC} Duty Cycle = 0%		
	Typical (years)	Worst Case (years)	
-40	> 20	> 20	>> 20
-30	> 20	> 20	>> 20
-20	> 20	> 20	>> 20
-10	> 20	17.9	>> 20
0	18.6	15.5	>> 20
10	16.1	12.5	>> 20
20	14.0	10.3	>> 20
25	12.6	9.5	>> 20
30	11.3	7.5	>> 20
40	8.6	5.2	>> 20
50	5.7	3.3	>> 20
60	4.1	2.2	> 20
70	2.6	1.3	11.0
80	1.4	0.8	4.3
85	1.3	0.6	2.7

Table 20. Data from M48T86 Device

Temperature (°C)	CAPHAT or SNAPHAT (BR1225, 48mAh)	SNAPHAT (BR1632, 120mAh)	V _{CC} Duty Cycle = 100%, Shelf Life (years)
	V _{CC} Duty Cycle = 0%, Typical (years)		
0	13.4	> 20	>> 20
10	13.2	> 20	>> 20
20	13.1	> 20	>> 20
25	13.0	> 20	>> 20
30	13.0	> 20	>> 20
40	12.9	> 20	>> 20
50	12.8	> 20	>> 20
60	12.7	> 20	> 20
70	11.0	11.0	11.0

APPENDIX D. SERIAL RTC PRODUCTS

Table 21. Data from M41T56/C64/94/315 and M41ST84/85/87/95 Ind. Temp. (MH6) Devices

Temperature (°C)	SNAPHAT (BR1632, 120mAh)	
	V _{CC} Duty Cycle = 0%	V _{CC} Duty Cycle = 100%, Shelf Life (years)
	Typical (years)	
-40	> 20	>> 20
-30	> 20	>> 20
-20	> 20	>> 20
-10	> 20	>> 20
0	> 20	>> 20
10	> 20	>> 20
20	> 20	>> 20
25	> 20	>> 20
30	> 20	>> 20
40	> 20	>> 20
50	> 20	>> 20
60	> 20	> 20
70	11.0	11.0
80	4.3	4.3
85	2.7	2.7

Table 22. Data from M41T00/S, M41T11, and M41T81/S Industrial Temperature (MH6) Devices

Temperature (°C)	SNAPHAT (BR1632, 120mAh)	
	V _{CC} Duty Cycle = 0%	
	Typical (years)	
-40	> 20	>> 20
-30	> 20	>> 20
-20	> 20	>> 20
-10	> 20	>> 20
0	> 20	>> 20
10	> 20	>> 20
20	> 20	>> 20
25	> 20	>> 20
30	> 20	>> 20
40	> 20	>> 20
50	> 20	>> 20
60	> 20	> 20
70	11.0	11.0
80	4.3	4.3
85	2.7	2.7

REVISION HISTORY

Table 23. Document Revision History

Date	Rev. #	Description of Revision
13-Oct-1998	0.0	Document written
14-Dec-98	1.0	1st Edition of ZEROPOWER and TIMEKEEPER Application Note Book
07-Mar-00	1.1	Data changed from that of 49mAh and 130mAh batteries to that of 48mAh and 120mAh batteries
25-Apr-00	1.2	Controllers renamed as Supervisors
26-Jun-00	1.3	M48T35 typ data retention lifetime changed to 7/10 years (Tab-7 on p15)
08-May-01	2.0	Reformatted, text, graphics, values updated (figures 6 , 7 , 8 , 10 ; tables 3 , 5 , 6 , 7 , 10 , 20 , 16 , 18 , 17 , 19 , 21 , 22)
15-May-01	2.1	Change trend colors to black (Figure 6 , 7 , 8 , 10)
31-May-05	3.0	Update information (Figure 1 , 6 , 7 , 8 , 9 , 10 ; Table 1 , 3 , 5 , 6 , 7 , 8 , 9 , 10 , 12 , 13 , 14 , 15 , 16 , 17 , 18 , 19 , 21 , 22)

CONTACT INFORMATION

If you have any questions or suggestions concerning the matters raised in this document, please send them to the following electronic mail addresses:

apps.nvram@st.com

(for application support)

ask.memory@st.com

(for general inquiries)

Please remember to include your name, company, location, telephone number, and fax number.

Information furnished is believed to be accurate and reliable. However, STMicroelectronics assumes no responsibility for the consequences of use of such information nor for any infringement of patents or other rights of third parties which may result from its use. No license is granted by implication or otherwise under any patent or patent rights of STMicroelectronics. Specifications mentioned in this publication are subject to change without notice. This publication supersedes and replaces all information previously supplied. STMicroelectronics products are not authorized for use as critical components in life support devices or systems without express written approval of STMicroelectronics.

The ST logo is a registered trademark of STMicroelectronics.

All other names are the property of their respective owners

© 2005 STMicroelectronics - All rights reserved

STMicroelectronics group of companies
Australia - Belgium - Brazil - Canada - China - Czech Republic - Finland - France - Germany - Hong Kong - India - Israel - Italy - Japan -
Malaysia - Malta - Morocco - Singapore - Spain - Sweden - Switzerland - United Kingdom - United States of America
www.st.com